

NOTES (UNLESS OTHERWISE NOTED):

- CONSTRUCTION:
 STAMPINGS: CuNiSi (LAMINATIONS) & COPPER (SMT BASE)
 HOUSING: GLASS-FILLED PPA
 PLATING: POST-PLATED SILVER OVER SULFAMATE NICKEL (LAMINATIONS AND SMT BASE)
- TYPICAL ASSEMBLY FORCES FOR MATING BLADE INTO LAMINATIONS:
 APPROXIMATELY 90N TYPICAL FOR 0.8mm BUSBAR
 APPROXIMATELY 205N TYPICAL FOR 1.0mm BUSBAR
 NOT APPROVED FOR USE OF 0.8mm BUSBAR AFTER INSERTION AND REMOVAL OF 1.0mm BUSBAR.
 HOWEVER, ACTUAL INSERTION FORCE DEPENDENT ON MATING BLADE THICKNESS, PLATING, LEAD-IN GEOMETRY, BLADE RAW MATERIAL AND INSERTION SPEED.
- MATING CYCLES:
 TESTED TO 3 CYCLES WITH CONTROLLED, REPEATABLE ASSEMBLY METHOD.
- MAXIMUM ENVIRONMENTAL TEMPERATURE: 125 °C.
- SUGGESTED SOLDER MASK DEFINED SOLDER PAD IS OPTIMIZED FOR PART PLACEMENT AND ORIENTATION.
- COPPER PAD UNDER SOLDER MASK GEOMETRY ADJUSTABLE PER APPLICATION REQUIREMENTS.
- USERS MUST ALWAYS VALIDATE AND QUALIFY BusMate® IN THEIR OWN APPLICATION.
- UNDER RARE CIRCUMSTANCES, A SHIFT IN THE LAMINATIONS MAY OCCUR. HOWEVER, SHIFT LESS THAN 0.55mm WILL NOT AFFECT THE INSERTION PROCESS. REALIGNMENT IF THE LAMINATION IS ALSO POSSIBLE WITHOUT DEGRADATION OF THE CONTACT SURFACE.
- CLEANLINESS REQUIREMENT: MAXIMUM 500µm METALLIC PARTICLE IS ALLOWED.

REVISIONS				
REV.	DESCRIPTION	DATE	APPROVED	DCN
A	INITIAL RELEASE	2020/12/17	GT	
B	UPDATED SOLDER PAD, HOUSING WIDTH	2021/5/27	GT	202112
C	ADDED DETAILS FOR 1mm BUSBAR	2021/9/2	GT	202113
D	REMOVED REDUNDANT DIMENSIONS	2021/11/12	GT	202119
E	(7.6) WAS 7.60±0.15; (9) WAS 9.00±0.15; ADDED DATUMS A, B, C	2022/12/13	GT	202301
F	REMOVED REFERENCE INDICATION, 0.63/0.58 WAS (0.61)	2023/1/23	GT	202302
G	7.6±0.15 WAS (7.6); 9±0.15 WAS (9); ADDED GRIPPER IMAGE	2023/8/4	GT	202311
H	UPDATED NOTE 2, ADDED NOTE 8	2024/2/14	GT	202402
J	ADD CLEANLINESS SPEC, PACKAGE INFO AND TOLERANCE MODIFICATION	2024/7/3	JK	202410

**ENNOVI PART#
IPX30035**

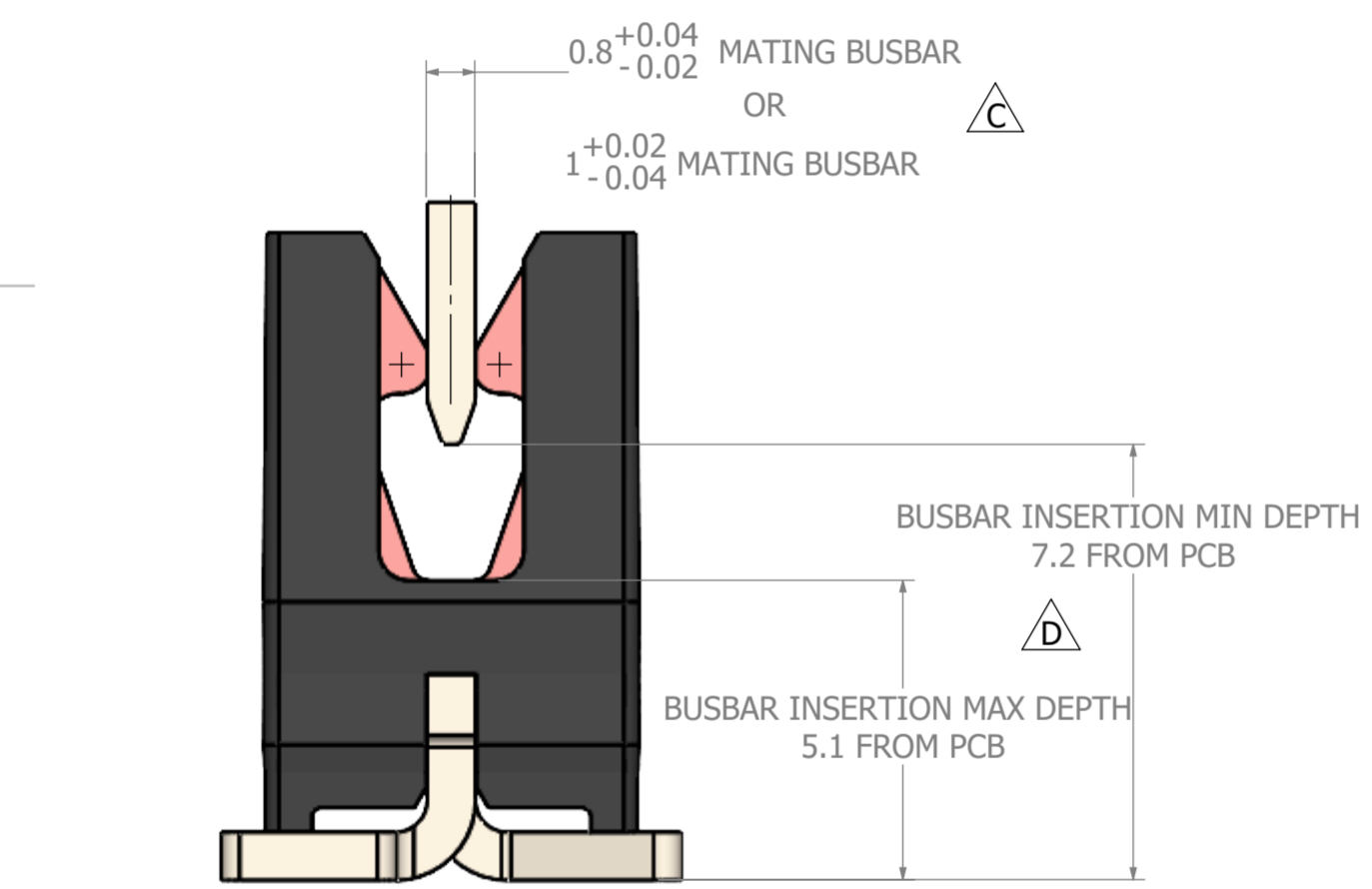
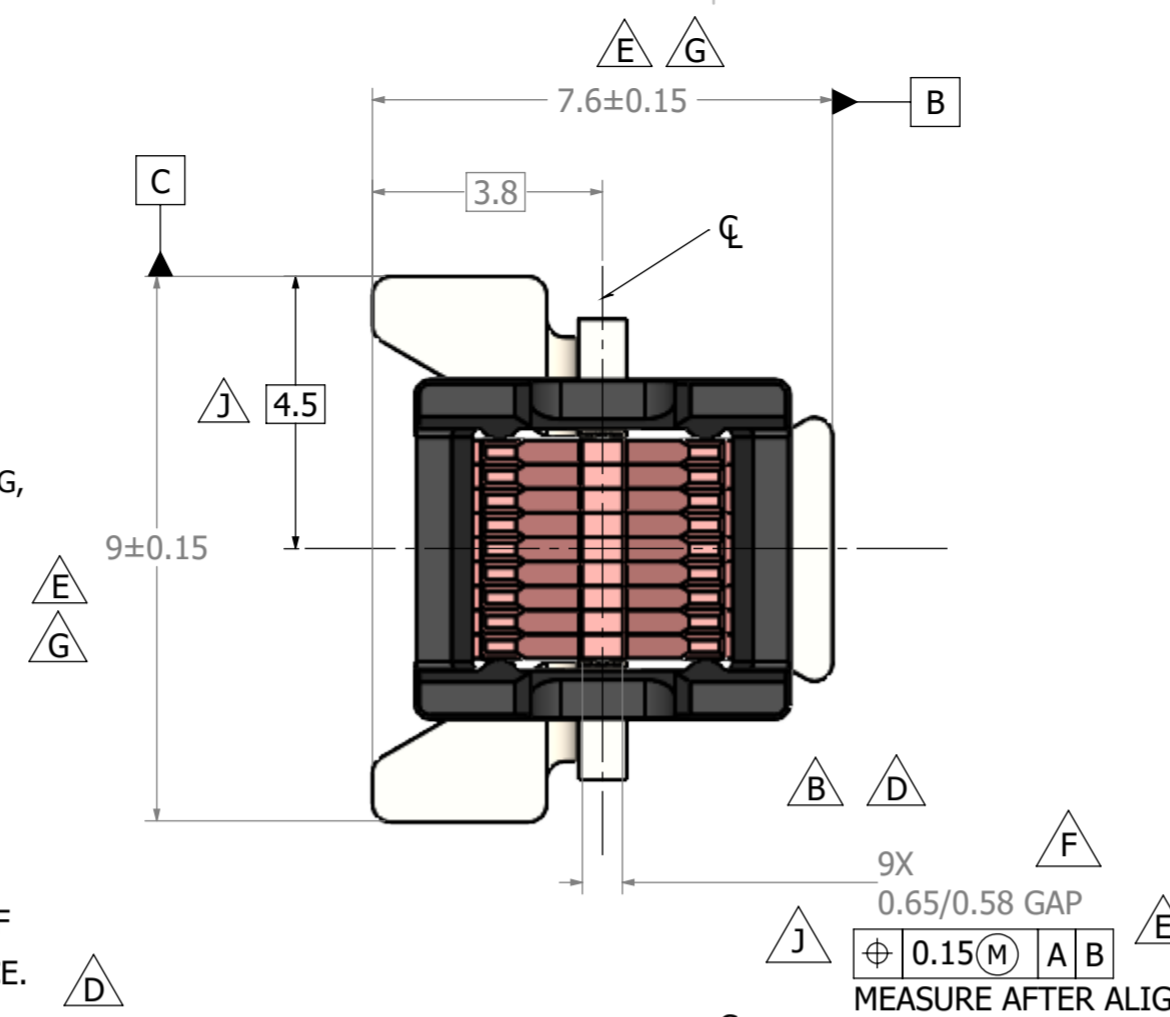
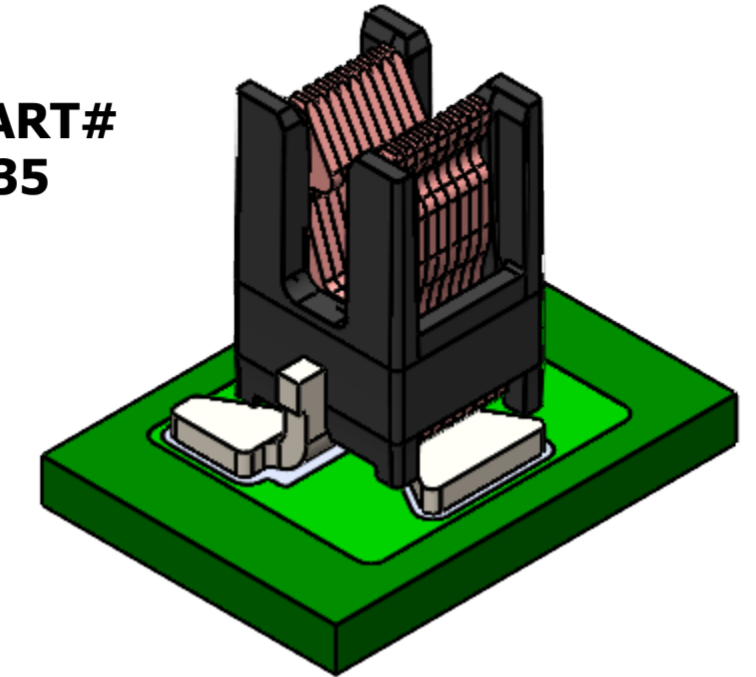

MATING BUSBAR
 BUSBAR MATERIAL: COPPER / COPPER ALLOY, 1/2 HARD MIN RECOMMENDED
 RECOMMENDED PLATING: Sn over Ni
 RECOMMENDED BLADE WIDTH: 5.6mm MIN

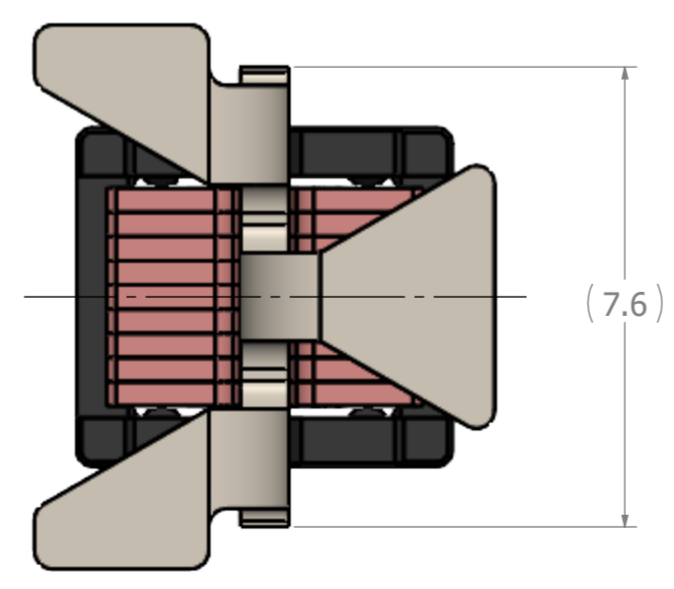
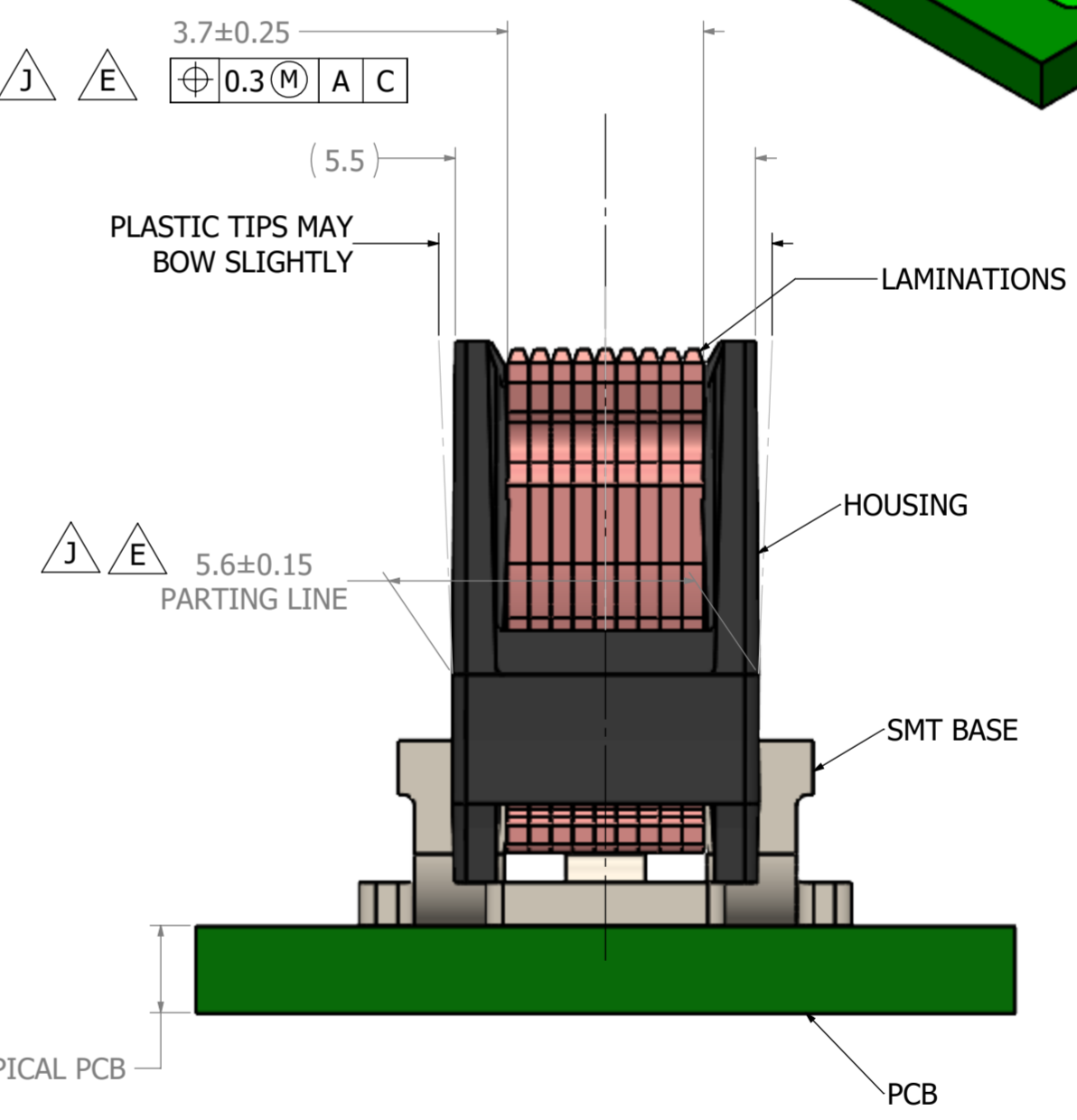
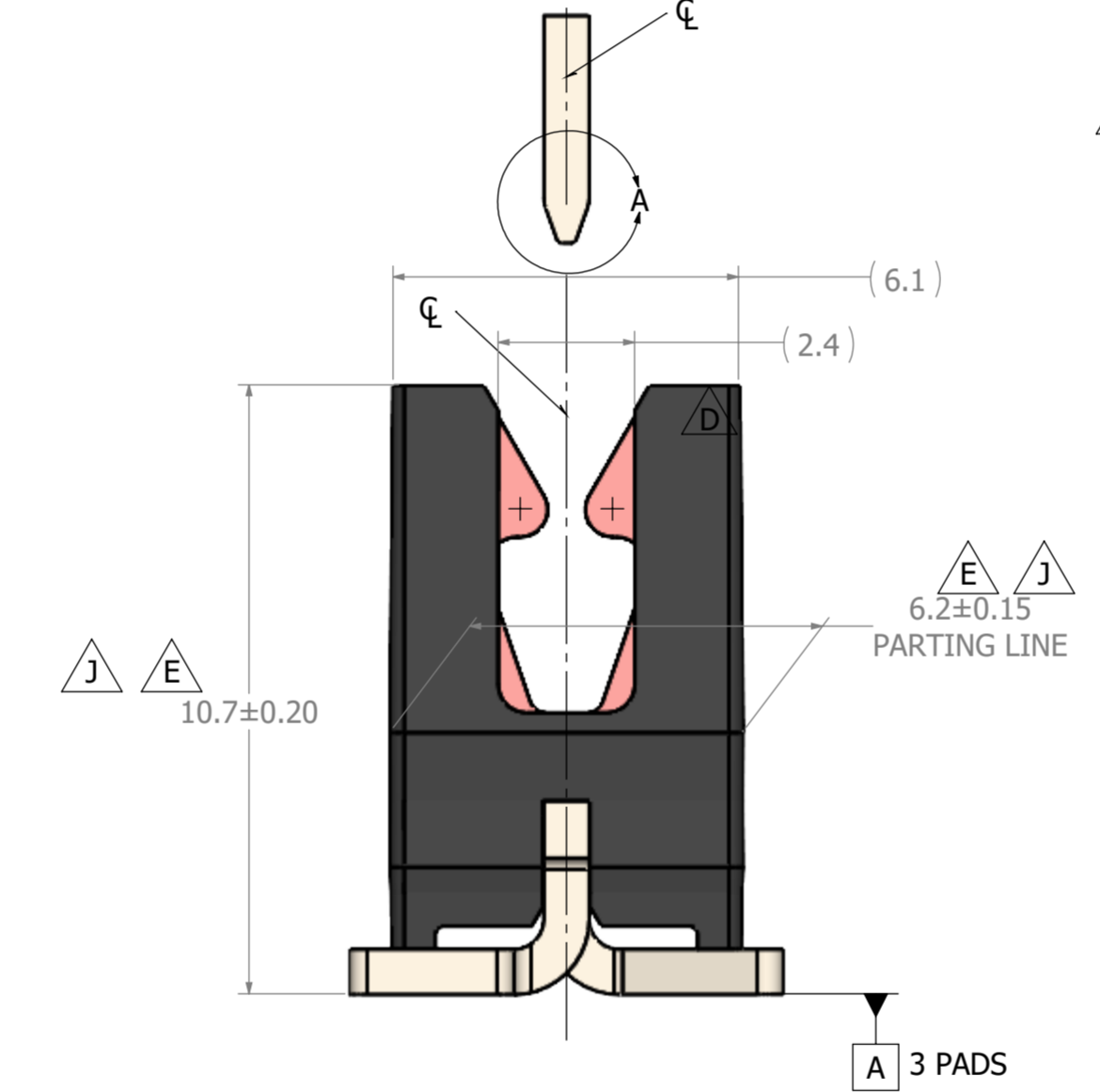
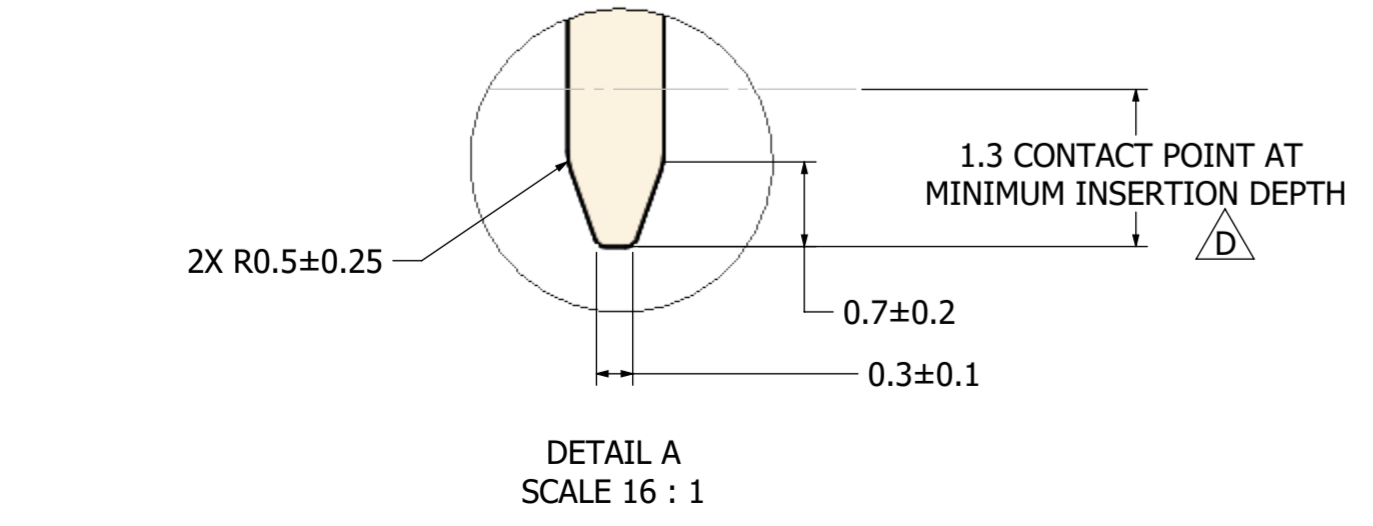

UNLESS OTHERWISE SPECIFIED:
 DIMENSIONS ARE IN MM
 TOLERANCES:
 .X ±.1
 .XX ±.07
 .XXX ±.03
 ANGULAR: ±2°

ENNOVI™ TITLE: BusMate®, 9 LAM SMT 40-60 AMP, 0.8mm/1.0mm MATING BUSBAR		SCALE:	SIZE:
		8:1	A2
DRAWING NO.: E-IPX30035		REV:	SHEET:
		J	1 / 2

REEL PACKAGING

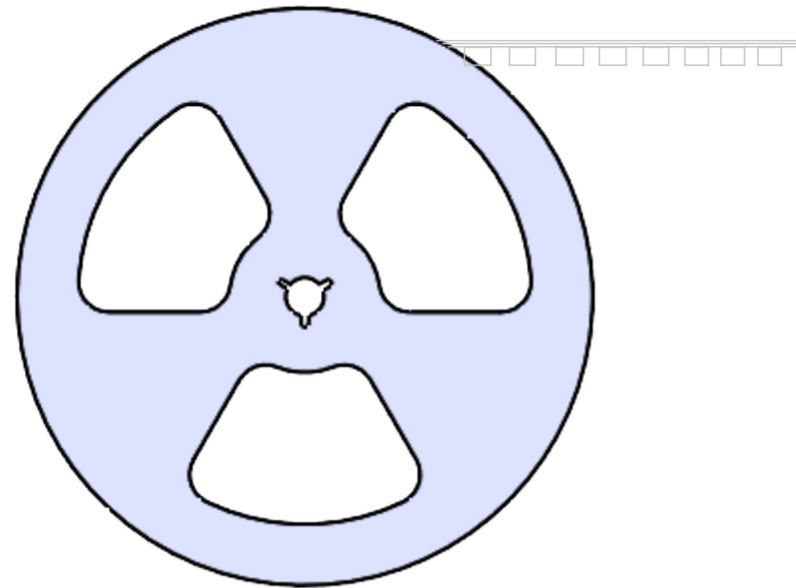

(TRAY PACKAGING ALSO AVAILABLE)

	REEL DIAMETER	TAPE WIDTH	PART PITCH	QTY PER REEL
1	380mm(15")	24mm	16mm	520 PCS
2				
3				

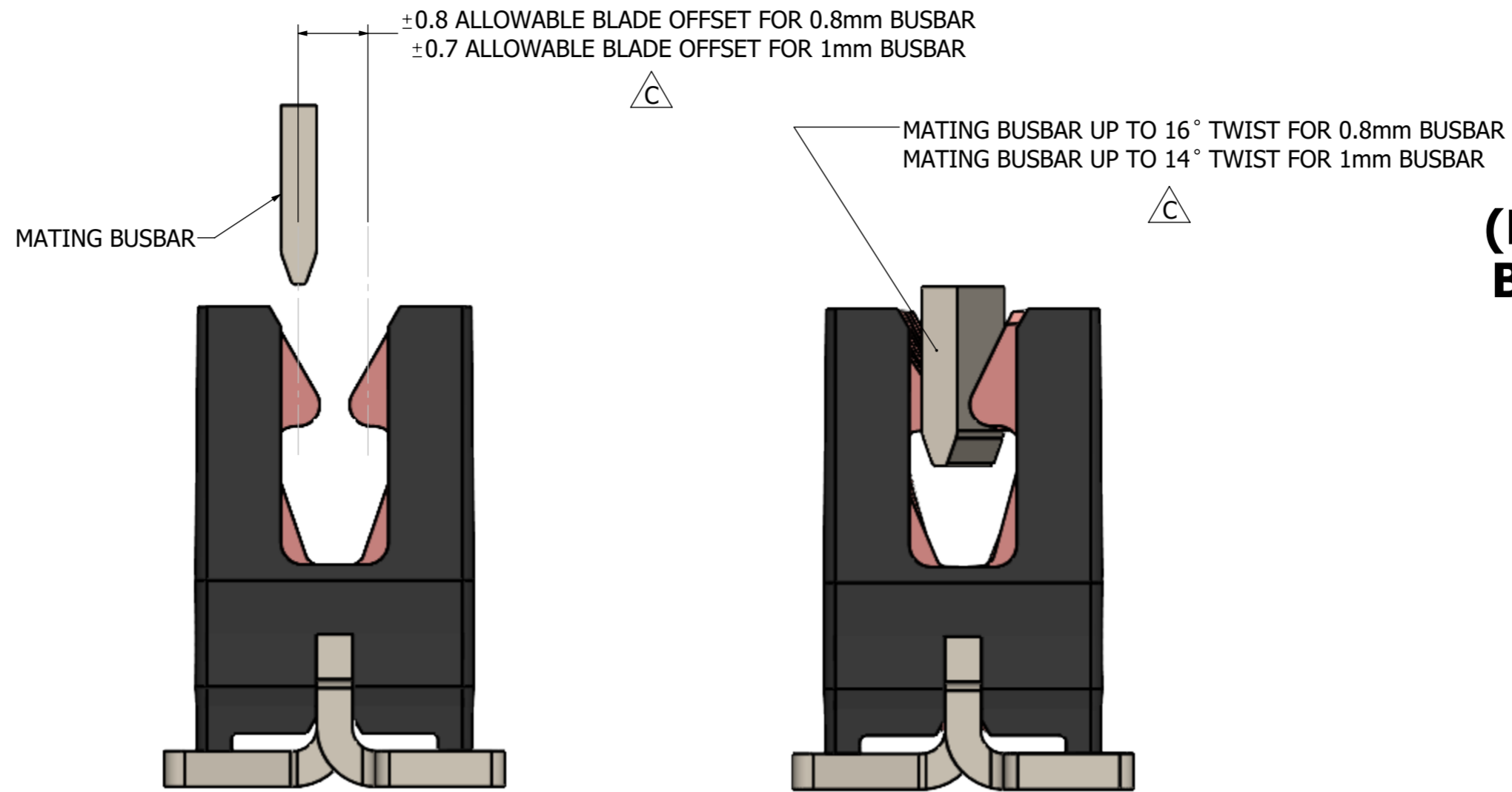

GRIPPER GEOMETRY (RECOMMENDED/PREFERRED BUSMATE PICKING METHOD)

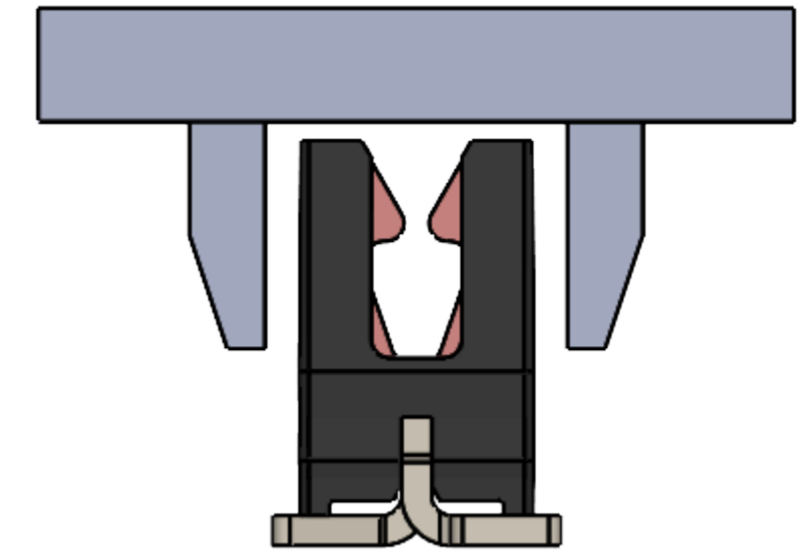

SUGGESTED SOLDER MASK DEFINED SOLDER PAD AND COPPER PAD UNDER SOLDER MASK LAYOUT

RECOMMEND: SAC305 SOLDER PASTE, 5 Mil THICK

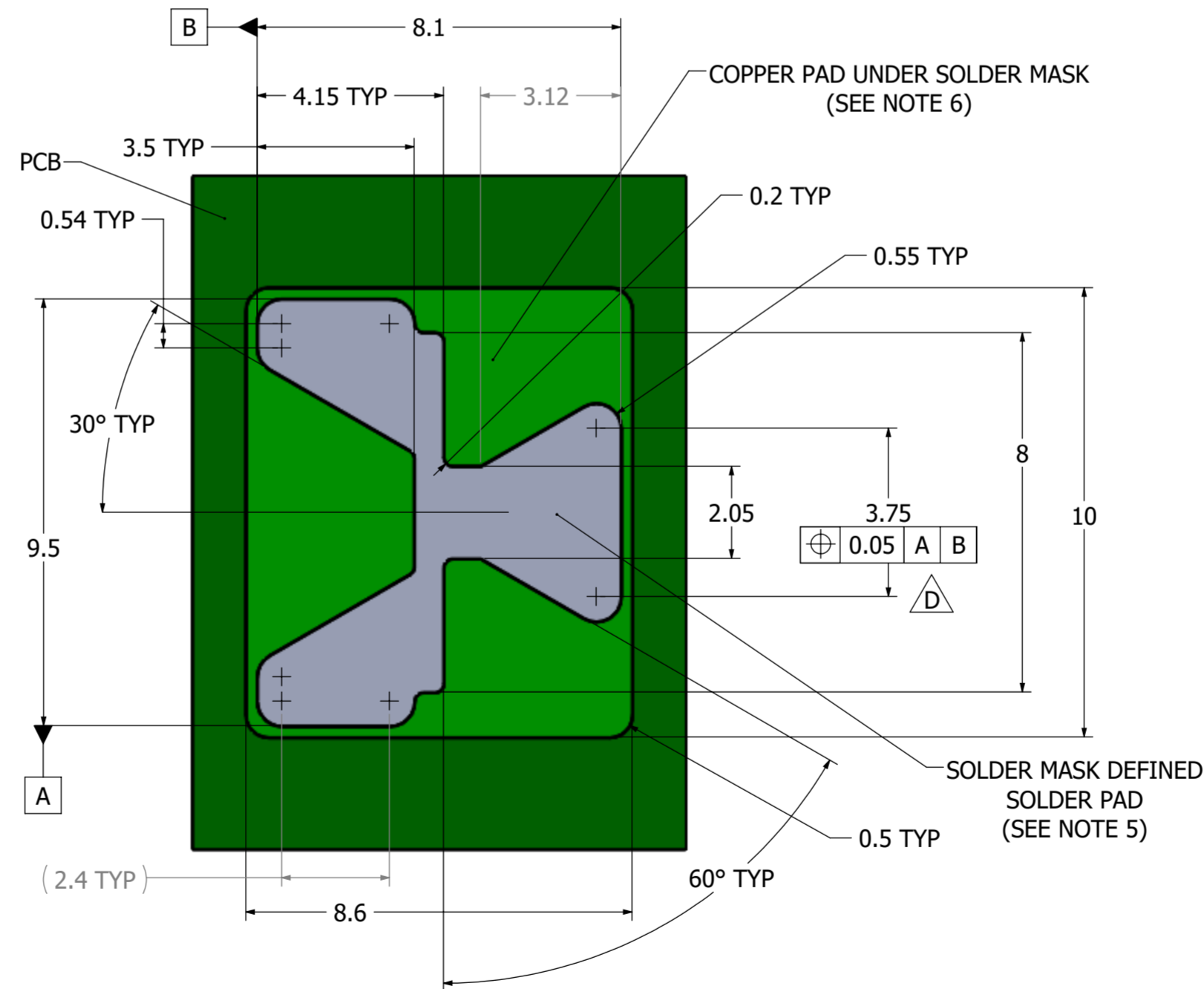

VACUUM NOZZLE TIP GEOMETRY

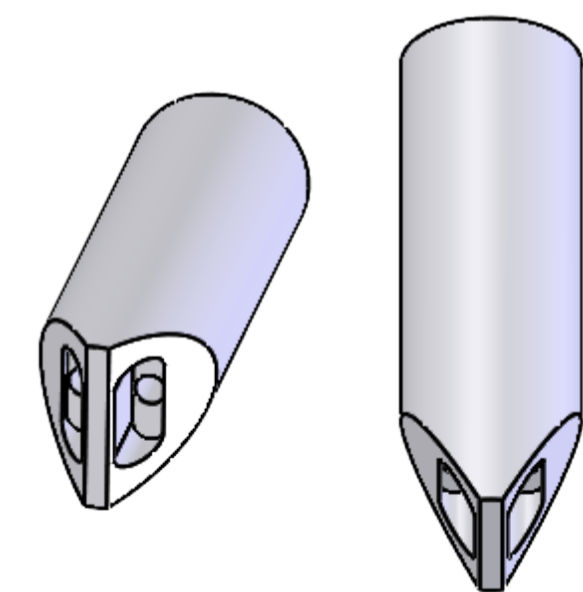

CONSULT ENNOVI FOR VENDOR
INFORMATION

UNLESS OTHERWISE SPECIFIED:
DIMENSIONS ARE IN MM
TOLERANCES:
.X ±.1
.XX ±.07
.XXX ±.03
ANGULAR: ±2°

ENNOVI™

TITLE:	BusMate®, 9 LAM SMT 40-60 AMP, 0.8mm/1.0mm MATING BUSBAR	SCALE:	8:1	SIZE:	A2
DRAWING NO.:	E-IPX30035	REV:	J	SHEET:	2 / 2