

ENNOVI

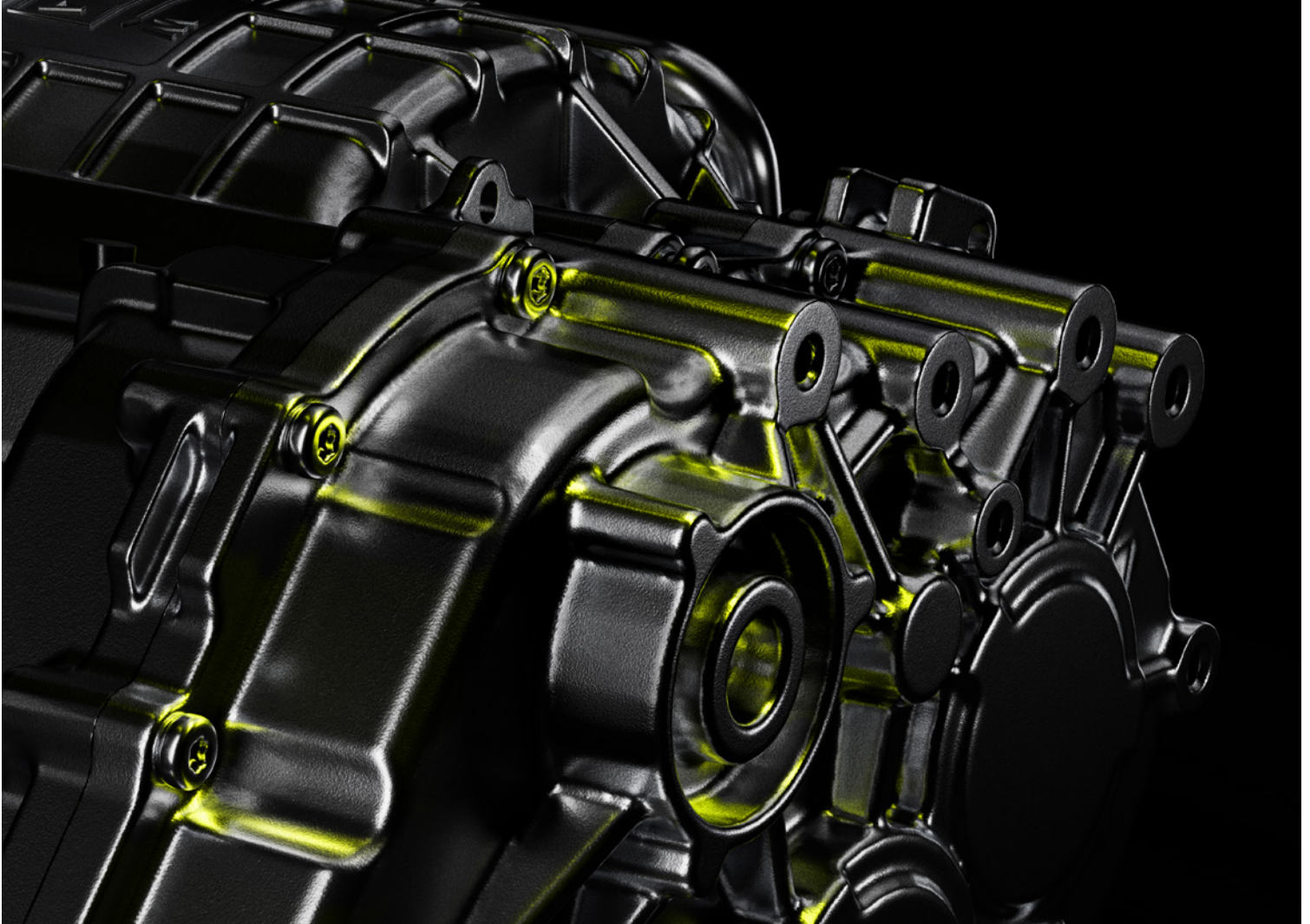

As hybrid and electric vehicles evolve and global competition increases, the need for higher power densities in drivetrains, inverters, converters, and other modules is a key differentiator. Our extensive range of busbars and interconnects help car makers deliver the power densities needed to extend vehicle range and performance, while improving time-to-market.

- + Custom integration of busbar form factors
- + Providing shorter current paths between assemblies
- + Optimizing conductance and minimizing resistance
- + Compact, small-footprint, pluggable solutions
- + Vertical integration of stamping, molding, and customization

INVERTER

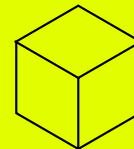
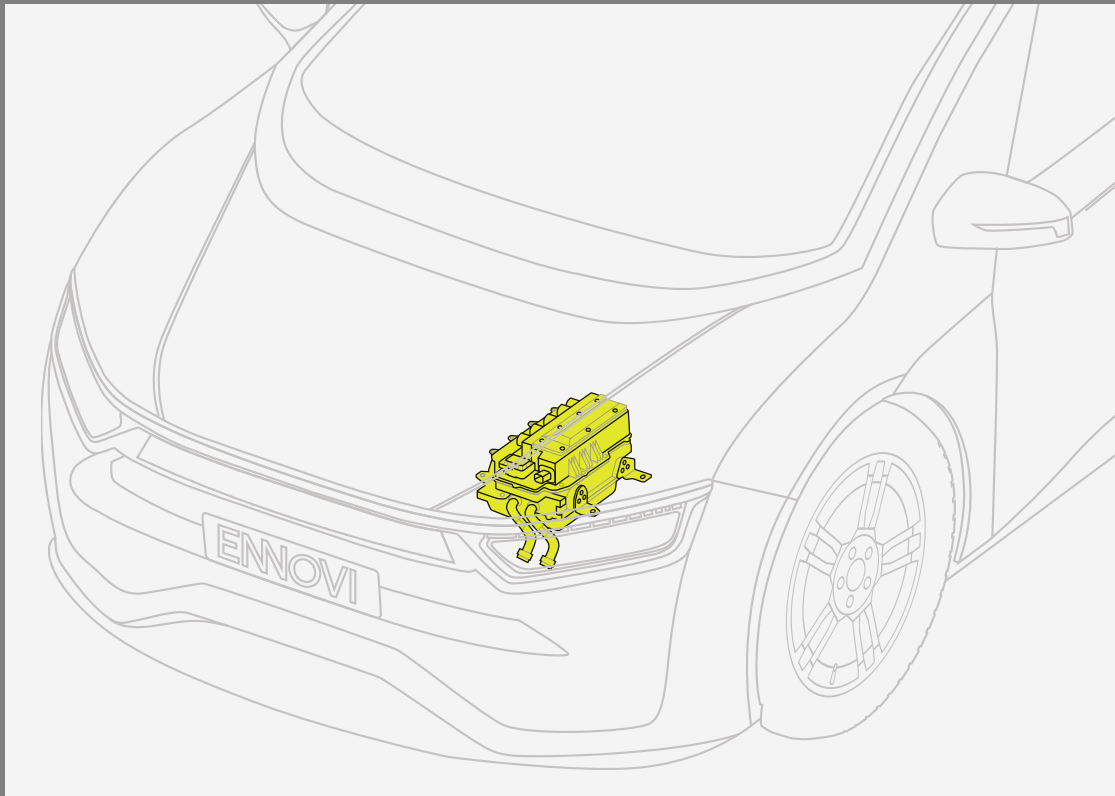

OUR PRODUCTS

- + Power Busbar
PCB Connector,
ENNOVI-BusMate
- + Flexible Multilayer Busbar
- + Phase Busbar
- + Power Module Lead Frame
- + High Power Connector
- + AC & DC Molded Busbar
- + Power Filter Module



CHALLENGES

- + Demand for **increasing power density** and **faster switching speed** in today's power inverter applications.
- + These applications with higher voltages need **better insulation** and **robust dielectric materials**.



SOLUTIONS

- + Our solutions are **thermal and chemical resistant**, delivering optimal electrical performance and power efficiency.
- + We resolve design challenges and help **fast-track the design cycle**.
- + Our **vertically integrated capabilities** and **global footprint** ensure the meeting of production schedules.

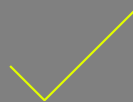

BENEFITS

- + Solutions customized to end applications enable **smaller and faster DC-AC inverters** that are robust and thermally efficient.
- + **High production volumes** that meet **stringent quality standards** for longer product lifecycles.

↳ CONVERTER

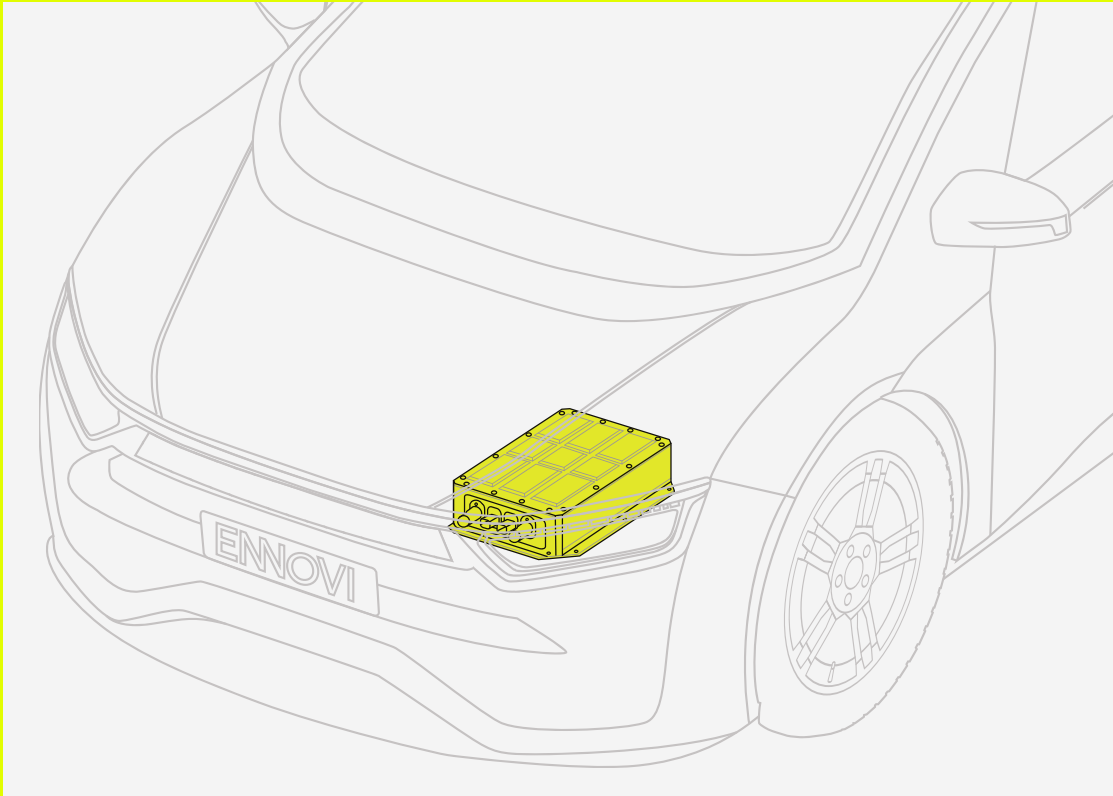

OUR PRODUCTS

- + Power Busbar
PCB Connector,
ENNOVI-BusMate
- + Power Module
Lead Frame
- + High Power
Connector
- + AC & DC Molded
Busbar



CHALLENGES

- + **Reliability is a key concern** due to the proliferation of devices that need converters for power.
- + Application requirements include **stringent size and weight constraints and high standards for durability**.



SOLUTIONS

- + Our solutions preserve space and weight and assure **reliable, robust operation in harsh conditions**.
- + We resolve design challenges and help **fast-track the design cycle**.
- + Our **vertically integrated capabilities and global footprint** ensure the meeting of production schedules.



BENEFITS

- + Solutions customized to end applications enable **smaller and faster DC-DC converters** that are robust and thermally efficient.
- + **High production volumes that meet stringent quality standards** for longer product lifecycles.

↙ ELECTRIC TRACTION MOTOR

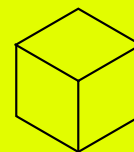
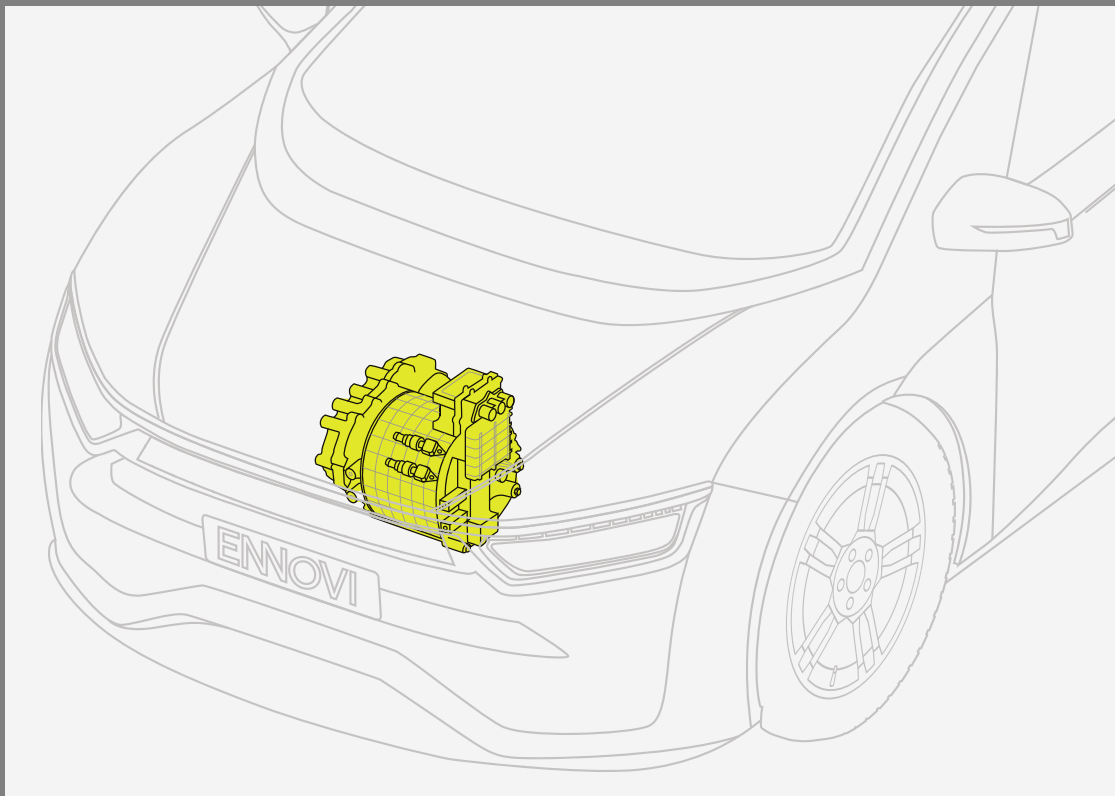

OUR PRODUCTS

- + Motor Stator Busbar
- + Phase Busbar
- + Flexible Busbar
- + Busbar Sealing Technology, ENNOVI-SealTech



CHALLENGES

- + **The ability to handle complex AC phase connections** is key for the transition of DC motors to AC motors, which delivers more power and torque.
- + **Bulky and costly windings on motor stators** need to be simplified to deliver top performance in harsh conditions.



SOLUTIONS

- + Our busbar solutions enable **complex AC multi-phase connections** in harsh conditions.
- + **We resolve design challenges** and ensure manufacturability, electrical efficiency and cost effectiveness.
- + **Our vertically integrated capabilities and global footprint** ensure the meeting of production schedules.

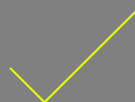

BENEFITS

- + Solutions customized to end applications enable **smaller, lighter, and highly-efficient AC traction motors**.
- + **The busbars have low potential points of failure**, resulting in better overall EV performance, range, and lifecycle.
- + **Elimination of wiring errors** and reduction in assembly time result in reduced risk and Total Cost of Ownership.

ON-BOARD CHARGER

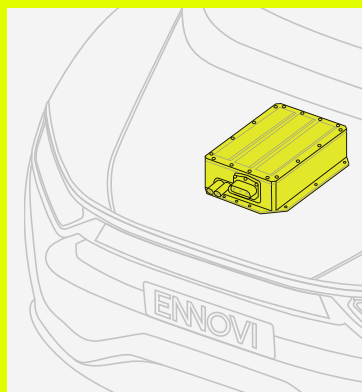

OUR PRODUCTS

- + Power Busbar
PCB Connector,
ENNOVI-BusMate
- + High Power Connector



CHALLENGES

- + **Slow EV charging processes** are a key concern for end consumers.
- + **The rise of two-way charging and Smart-Charging** is adding complexity due to the need for built-in intelligence.
- + Application requirements have **tight size and weight constraints**.



SOLUTIONS

- + Our ENNOVI-BusMate and connectors **reduce size and complexity** while assuring **robust high-power transmission**.
- + **We solve the application design challenges** of complex two-way charging, Smart-Charging, and charging from multi-phase AC sources.
- + **Our vertically integrated capabilities and global footprint** ensure the meeting of production schedules.



BENEFITS

- + Solutions customized for end applications enable **smaller, lighter, and robust on-board chargers**.
- + Connectors for the full range of two-way, Smart-Charging, and AC charging are **provided from one supplier**.
- + **High quality standards** enable longer product lifecycles.

ELECTRIC POWER STEERING

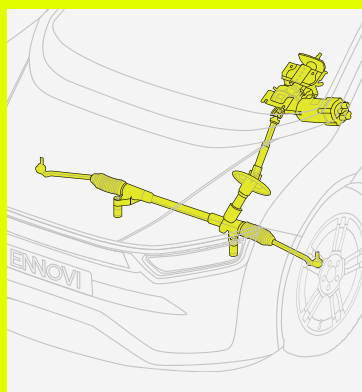

OUR PRODUCTS

- + Power Busbar
PCBConnector,
ENNOVI-BusMate
- + Motor Stator Busbar
- + Power Filter Module



CHALLENGES

- + **Tight integration of complex power and signaling** is needed between multiple modules.
- + **Interfaces between power and control PCBs** and external interfaces to power steering motors are critical for success.



SOLUTIONS

- + Our ENNOVI-BusMate busbars, and custom solutions combine to support **reliable power and signaling**.
- + ENNOVI-BusMate **simplifies the assembly of robust power interfaces**.
- + **Our vertically integrated capabilities and global footprint** ensure achievement of production schedules.



BENEFITS

- + Our customizable solutions enable integrated power steering systems in **small, low-weight form factors**.
- + **High production volumes that meet stringent quality standards** provide longer product lifecycles and reduced Total Cost of Ownership.

Applications & Capabilities

ENNOVI power interconnects, busbars and lead frames are fully customizable across a range of applications within hybrid and EV power systems. The table below provides a quick reference regarding applications and capabilities for the various ENNOVI offerings.

The table below provides a quick reference regarding applications and capabilities for the various ENNOVI offerings.

PRODUCTS	PHASE BUSBAR →	AC & DC MOLDED BUSBAR	MOTOR STATOR BUSBAR →	FLEXIBLE MULTILAYER BUSBAR →
IMAGES				
APPLICATIONS	Inverter Electric Traction Motor	Inverter Converter	Electric Traction Motor Electric Power Steering	Inverter Electric Traction Motor
CAPABILITIES	Precision Stamping Insert Molding Overmolding Plating Brazing Green Laser Welding Dispensing and Curing (Sealant) Electrical Function & HIPOT Testing Leak Testing Automation Assembly	Precision Stamping Overmolding Plating Brazing Crimp & Weld Component Attachment Integration - Current & Temperature Sensors Diffusion Bonding Electrical Function & HIPOT Testing Automation	Precision Stamping Insert Molding Overmolding Plating Brazing Green Laser Welding Electrical Function & HIPOT Testing Automation Assembly	Precision Stamping Brazing Diffusion Bonding Dispensing and Curing Electrical Function & HIPOT Testing Automation

PRODUCTS	POWER BUSBAR PCB CONNECTOR, ENNOVI-BUSMATE →	HIGH POWER CONNECTOR	POWER MODULE LEAD FRAME	POWER FILTER MODULE
IMAGES				
APPLICATIONS	Inverter Converter On-board Charger Electric Power Steering	Inverter Converter On-board Charger	Inverter Converter	Inverter Electric Power Steering
CAPABILITIES	Precision Stamping Press-Fit or Surface Mount Configuration Mechanical & Electrical Testing Assembly	Precision Stamping Insert Molding Overmolding Plating Sealing Dispensing and Curing (Sealant) Brazing Green Laser Welding Electrical Function & HIPOT Testing Leak Testing Automation Assembly	Precision Stamping Brazing Overmolding Plating Dispensing and Curing Electrical Function & HIPOT Testing Leak Testing Automation Assembly	Precision Stamping Insert Molding Overmolding Plating Dispensing and Curing (Seal and Epoxy) Green Laser Welding Electrical Function & HIPOT Testing Integration - Capacitors & Resistors Leak Testing Automation Assembly

Our Technologies

Our end-to-end technical skills, design experience and manufacturing expertise enable us to innovate game-changing technologies.

Enabling optimal performance and power efficiency in smaller packaging with our game-changing technologies.

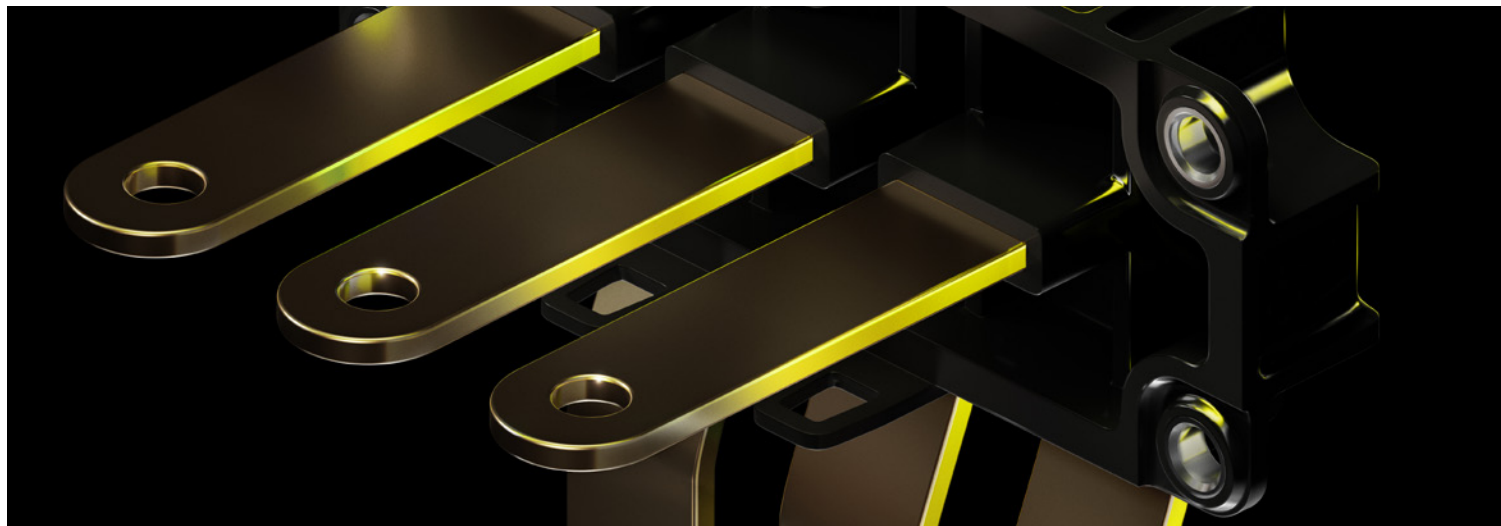

TECHNOLOGIES

BUSBAR SEALING TECHNOLOGY →

HV EXTRUDED BUSBAR TECHNOLOGY →

IMAGES

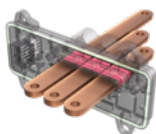

APPLICATIONS

Motors, inverters or oil pump interfaces:

- + Phase Busbar
- + Motor Stator Busbar

Battery pack, battery junction box and power distribution unit:

- + Battery Interconnects

Need a custom solution?

CONTACT US



© 2025 ENNOVI
ALL RIGHTS RESERVED

FOLLOW US ON
[LINKEDIN](#)
[YOUTUBE](#)
[WECHAT](#)

VISIT [ENNOVI.COM](https://www.ennovi.com)
FOR MORE DETAILS

ENN-PWR-01-EN-002

ENNOVI™